

# DH-HAP100

## Pinhole Pickup



### Features

- Omni-directional condenser microphone, high fidelity;
- 30KV Air contact ESD, built-in Lightning Protection, power supply polarity reversal protection and electrostatic protection;
- Pinhole design, hidden installation; match with cameras or storage devices which have audio function!

## Technical Specifications

<b>Model</b>	<b>DH-HAP100</b>
<b>General</b>	
Scope	5-40m <sup>2</sup>
Sensitivity	-40dB(-45~-20dB adjustable)
Frequency response	20Hz~20kHz
Directional characteristic	Omni-directional
SNR	70dB(1m 40dB sound source SPL)
Dynamic range	104dB(1KHz at Max dB SPL)
Max. sustainable sound pressure	120dB SPL(1KHz, THD 1%)
Output impedance	600Ω(non-equilibrium)
Output signal amplitude	2.5Vpp/-25dB
Working voltage	DC 12V(9~15V)
Working current	60mA(50~100mA)
Working temperature	-30°C ~ +70°C (-22°F ~ +158°F)
Color	White
Outer shell	PC
Dimension	63mmx30mmx22mm(2.48"x1.18"x0.87")
Weight	34g(0.07lb)
Carried standard	CE/FCC

## Dimensions (mm/inch)

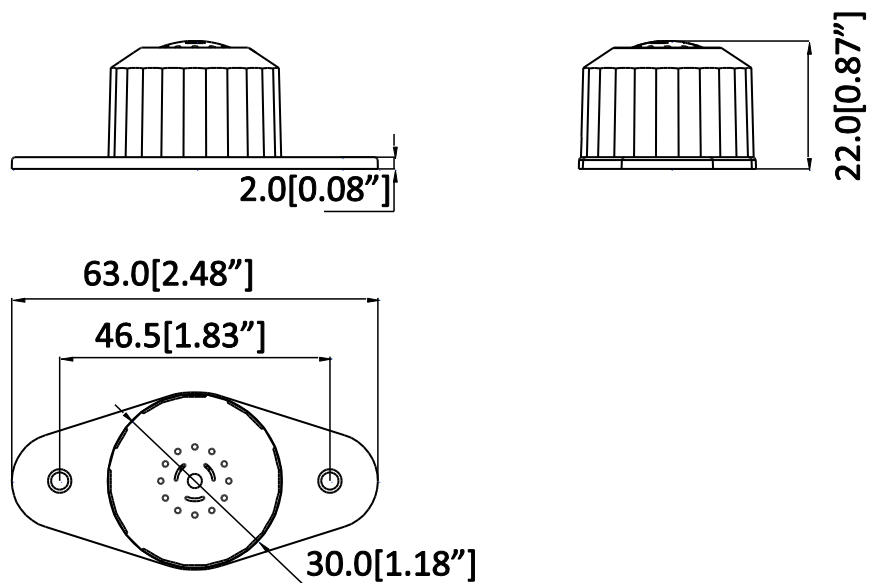

## Package Information

- Pinhole pickup \*1
- ST4x25 screw \*3
- Plastic anchor \*3
- Mounting sticker\*1